

Bill as Introduced

HB 1405 - AS INTRODUCED

2010 SESSION

10-2552

06/03

HOUSE BILL **1405**

AN ACT relative to reverse signal operation safety requirements for construction equipment.

SPONSORS: Rep. Baldasaro, Rock 3; Rep. Swinford, Belk 5; Rep. Sapareto, Rock 5; Rep. Griffin, Rock 4

COMMITTEE: Transportation

ANALYSIS

This bill establishes reverse signal operation safety requirements for construction equipment.

Explanation: Matter added to current law appears in **bold italics**.
Matter removed from current law appears ~~(in brackets and struckthrough.)~~
Matter which is either (a) all new or (b) repealed and reenacted appears in regular type.

STATE OF NEW HAMPSHIRE

In the Year of Our Lord Two Thousand Ten

AN ACT relative to reverse signal operation safety requirements for construction equipment.

Be it Enacted by the Senate and House of Representatives in General Court convened:

1 1 Short Title. This act shall be known as Rob's Law.

2 2 New Subdivision; Reverse Signal Operation Safety for Construction Equipment. Amend RSA
3 265 by inserting after section 159 the following new subdivision:

4 Reverse Signal Operation Safety for Construction Equipment

5 265:160 Applicability. This subdivision shall apply to all construction equipment capable of
6 operating in reverse and with an obstructed view to the rear, whether intended for operation in off-
7 road work zones or over the road transportation or hauling. As used in this subdivision, "obstructed
8 view to the rear" means anything that interferes with the overall view of the operator of the
9 equipment to the rear of the equipment at ground level, and includes, but is not limited to, such
10 obstacles as any part of the equipment, its load, its height relative to ground level viewing, damage
11 to windows or side mirrors used for rearview movement of the equipment, restricted visibility due to
12 weather conditions, or work being done after dark without proper lighting.

13 265:161 Requirements.

14 I. No individual shall operate any construction equipment in reverse unless:

15 (a) Such equipment has a reverse signal alarm audible above the surrounding noise
16 level; and

17 (b) Such equipment is operated in reverse only when a designated observer signals that
18 it is safe to do so or before operating such equipment in reverse, the driver visually determines that
19 no individual is in the path of such equipment.

20 II. Any construction equipment that was not equipped with a reverse-signal alarm upon
21 manufacture or was not later retrofitted with an alarm is exempt from subparagraph I(a). If the
22 manufacturer of the construction equipment offered the owner a reverse signal alarm retrofit
23 package at a reasonable and economically feasible cost and the owner did not have the retrofit
24 package installed, this exemption shall not apply.

25 III. Where immediate correction is not feasible, construction equipment equipped with a
26 reverse signal alarm that is not operational or is not functioning properly shall be either:

27 (a) Operated in reverse only when a designated observer signals that it is safe to do so; or

28 (b) Removed from service until the reverse signal alarm is repaired.

29 IV. Construction equipment with operable video or similar technological capability used by
30 the driver and capable of providing the driver with a full view behind the equipment is exempt from
31 subparagraph I(b).

1 265:162 Duties of Designated Observers and Drivers.

2 I. Any individual who is the designated observer during reverse signaling activities shall:

3 (a) Engage in activities related to the construction equipment being signaled.

4 (b) Refrain from the use of personal cellular phones, personal head phones, or similar
5 items that could pose a distraction for the designated observer.

6 (c) Wear during daytime operations a safety vest or jacket in orange, yellow, strong
7 yellow green, or fluorescent versions of these colors.

8 (d) Wear during nighttime operations a safety vest or jacket with retroreflective material
9 in orange, yellow, white, silver, strong yellow green, or a fluorescent version of these colors that are
10 visible at a minimum distance of 1,000 feet.

11 (e) Always maintain visual contact with the driver of the construction equipment while it
12 is operating in reverse.

13 (f) Maintain a safe working distance from the construction equipment.

14 II. When using a designated observer, no driver of construction equipment shall operate in
15 reverse unless he or she maintains constant visual contact with the designated observer. If visual
16 contact is lost, the driver shall immediately stop the equipment until visual contact is regained and a
17 positive indication is received from the designated observer to restart reverse operations.

18 3 Effective Date. This act shall take effect July 1, 2012.

Amendments



Rep. Baldasaro, Rock. 3
February 16, 2010
2010-0742h
06/09

Amendment to HB 1405

- 1 Amend the bill by replacing section 3 with the following:
- 2
- 3 3 Effective Date. This act shall take effect July 1, 2015.

Not Adopted

Committee Minutes

HOUSE COMMITTEE ON TRANSPORTATION

BILL NUMBER: HB 1405

BILL TITLE: relative to reverse signal operation safety requirements for construction equipment.

DATE: March 10, 2010

THE COMMITTEE HAS VOTED TO HOLD THIS BILL FOR INTERIM STUDY.



Robert Williams, Chairman

10-2552

06/03

HOUSE BILL 1405

House Bill 1405 is a bill relative to reverse signal operation safety requirements for construction equipment. This bill was initiated in response to the death of a construction worker when the noise of several construction vehicles made the usual backup warning system on the vehicles inadequate and ineffective. The problem was and is the blind spot which meant the operator can not have a rear view of the vehicle thus creating a blind spot.

The purpose of this bill was to make the work place safer by having all construction vehicles built in such a way or to have mirrors which gives the operator an overall view of the rear of the vehicle. The Sub-committee recommendation was I.T.L. after a full review of the bill. There is a need to let technology catch up which will be in a couple of years...

Richard Hinch

OK
Richard Hinch

HOUSE COMMITTEE ON TRANSPORTATION

INTERIM STUDY

EXECUTIVE SESSION on HB 1405

BILL TITLE: relative to reverse signal operation safety requirements for construction equipment.

DATE: October 13, 2010

LOB ROOM: 203

RECOMMENDED FOR FUTURE LEGISLATION

LSR No. _____
(If legislation is already filed, list LSR No.)

NOT RECOMMENDED FOR FUTURE LEGISLATION

Moved by Rep. Hinch

Seconded by Rep. Nedeau

Vote: 11-0 (Please attach record of roll call vote.)

Statement of Intent: Refer to Committee Report

Respectfully submitted,

Rep. C. Pennington Brown, Clerk

HOUSE COMMITTEE ON TRANSPORTATION

INTERIM STUDY

EXECUTIVE SESSION on HB 1405

BILL TITLE: relative to reverse signal operation safety requirements for construction equipment.

DATE: October 13, 2010

LOB ROOM: 203

RECOMMENDED FOR FUTURE LEGISLATION

LSR No. _____
(If legislation is already filed, list LSR No.)

NOT RECOMMENDED FOR FUTURE LEGISLATION

Moved by Rep. Hinch

Seconded by Rep. Nedeau.

Vote: (Please attach record of roll call vote.)

11 - 0

Statement of Intent: Refer to Committee Report

Respectfully submitted,

Rep. ~~C. Pennington-Brown~~, Clerk
Stephen Nedeau

TRANSPORTATION

Bill #: HB 1405 Title: REVERSE SIGNAL OPERATION

PH Date: ___/___/___

Exec Session Date: Oct / 13 / 2010

Motion: _____ Amendment #: _____

MEMBER	YEAS	NAYS
Williams, Robert W, Chairman	✓	
O'Brien, Michael B, V Chairman	✓	✓
Brown, Jennifer M	✓	
Brown, C. Pennington, Clerk	✓	✓
Ingersoll, Paul H	✓	✓
Hebert, Roger G	✓	
LaPlante, Roland H	✓	
Rhodes, Brian D	✓	
Rokas, Theodoros V	✓	
Soucy, Timothy A	✓	
Stuart, Richard T	✓	
Nedeau, Stephen H	✓	
Flanders, John W	✓	
Veazey, John A	✓	
Coffey, Jennifer R	✓	
Hikel, John A	✓	
Hinch, Richard W	✓	
Umberger, Karen C	✓	
Packard, Sherman A	✓	
BETH RODD	✓	
110		
TOTAL VOTE:		

Speakers

Hearing Minutes

HOUSE COMMITTEE ON TRANSPORTATION

PUBLIC HEARING ON HB 1405

BILL TITLE: relative to reverse signal operation safety requirements for construction equipment.

DATE: January 20, 2010

LOB ROOM: 203 **Time Public Hearing Called to Order:** 1:10 p.m.

Time Adjourned: 2:10 p.m.

(please circle if present)

Committee Members: Reps. R. Williams, Jennifer Brown, C. Brown, Ingersoll, M. O'Brien, Hebert, LaPlante, Rhodes, Rokas, T. Soucy, Stuart, Nedeau, G. Katsakiores, J. Flanders, Veazey, Coffey, Hikel, Hinch and Umberger.

Bill Sponsors: Rep. Baldasaro, Rock 3; Rep. Swinford, Belk 5; Rep. Sapareto, Rock 5; Rep. Griffin, Rock 4

TESTIMONY

* Use asterisk if written testimony and/or amendments are submitted.

Rep. Al Baldasaro, sponsor. Intent is to make construction sites safer.

Janet Augeri, mother of accident victim. Tragic story.

Chris Augeri, father of accident victim, "and" safety consultant. OSHA's laws are 30 years old and antiquated. Job sites noisy. Workers are forced to ignore alarms when heard. Backing up blind seems to be tolerated.

Peter McNamara, NH Auto Dealers' Assn. Oppose as drafted. Auto alarms relatively easy to retrofit. TV cameras are expensive. Membership objects to camera and/or spotter although they are not that involved in construction.

Mark Holden, Assn. of Builders & Contractors. Opposed, but not opposed to intent. OSHA regulations cover alarms and observers. Changes should be made with OSHA which would supersede state regulations.

Bruce Crawford, citizen. Oppose. Unfunded mandate, OSHA adequate.

Jasen A. Stock, NH Timberland Owners' Assn. Oppose. Question is logging construction? Many loggers work alone. What is "reasonable and economically feasible" re. cost. Not clear.

Robert Johnson, NH Farm Bureau. Oppose. Believes this needs to go to a subcommittee.

Gary Abbott, Associated General Contractors of NH. Oppose. Question of conflicting regulations including Federal Highway Administration. Technical equipment not always suitable for specific vehicles and equipment is evolving.

Respectfully submitted,

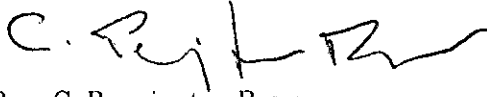
A handwritten signature in black ink, appearing to read "C. Pennington Brown". The signature is stylized and cursive, with a prominent "C" at the beginning and a long, sweeping underline.

Rep. C. Pennington Brown,
Clerk

HOUSE COMMITTEE ON TRANSPORTATION

PUBLIC HEARING ON HB 1405

BILL TITLE: relative to reverse signal operation safety requirements for construction equipment.

DATE: 1/20/10

LOB ROOM: 203 Time Public Hearing Called to Order: 1:10 PM

Time Adjourned: 2:10

(please circle if present)

Committee Members: Reps. R. Williams, Jennifer Brown, C. Brown, Ingersoll, M. O'Brien, Hebert, LaPlante, Rhodes, Rokas, T. Soucy, Stuart, Nedeau, G. Katsakiores, J. Clanders, Veazey, Coffey, Hikel, Hinch and Umberger.

Bill Sponsors: Rep. Baldasaro, Rock 3; Rep. Swinford, Belk 5; Rep. Sapareto, Rock 5; Rep. Griffin, Rock 4

TESTIMONY

* Use asterisk if written testimony and/or amendments are submitted.

- Rep.
- ① Al Baldasaro - sponsor intent is to make construction sites safer.
 - ② Janet Angeri - Mother of accident victim } tragic story.
 - ③ Chris Angeri - Father "and" safety consultant }
OSHA's laws are 30 years old and antiquated. Job sites noisy. Workers are forced to ignore alarms when heard. Backing up blind seems to be tolerated.
 - ④ Pete McNamara NH Auto Dealers Assn. ^{Oppose as drafted} - Auto alarms relatively easy to retrofit. TV ~~cameras~~ cameras are expensive. Membership objects to camera and/or spotter. although they are not that involved in construction.
 - ⑤ Mark Holden - Assoc of Builders + Contractors. Opposed, but not opposed to intent. OSHA regs cover alarms and observers. Changes should be made with OSHA which would supercede state regs.

over

- ⑥ Bruce Crawford - citizen Oppose. Unfunded mandate. OSHA ^{adequate}
- ⑦ Susan Stock - NH Timberland Owners Assoc. Oppose, Question, is logging construction? Many loggers work alone. What is "reasonable and economically feasible" re. cost. Not clear.
- ⑧ Robert Johnson; NH Farm Bureau - Oppose. Believes this needs to go to a subcommittee
- ⑨ Gary Abbott Associated General Contractors of NH. Oppose
Question of conflicting regs. incl. Federal Hwy. ~~Adm~~ Administration.
Technical equip not always suitable for specific vehicles and equip is evolving.

Sub-Committee Actions

HOUSE COMMITTEE ON TRANSPORTATION
SUBCOMMITTEE WORK SESSION ON HB 1405

BILL TITLE: relative to reverse signal operation safety requirements for construction equipment.

DATE: September 7, 2010

Subcommittee Members: Reps. Ingersoll, Hebert, Hinch, and Nedeau

Comments and Recommendations:

Amendments:

Sponsor: Rep.	OLS Document #:
Sponsor: Rep.	OLS Document #:
Sponsor: Rep.	OLS Document #:

Motions: OTP, OTP/A, ITL, Retained (Please circle one.)

Moved by Rep. Ingersoll

Seconded by Rep. Nedeau

Vote: 3-0

Motions: OTP, OTP/A, ITL, Retained (Please circle one.)

Moved by Rep.

Seconded by Rep.

Vote:

Respectfully submitted,

Rep. Ingersoll
Subcommittee Chairman/Clerk

HOUSE COMMITTEE ON TRANSPORTATION
SUBCOMMITTEE WORK SESSION ON HB 1405

BILL TITLE: relative to reverse signal operation safety requirements for construction equipment.

DATE: September 7, 2010

Subcommittee Members: Reps. Ingersoll, Hebert, and Nedeau *Rep Hinch*

Comments and Recommendations:

Amendments:

Sponsor: Rep. OLS Document #:

Sponsor: Rep. OLS Document #:

Sponsor: Rep. OLS Document #:

Motions: OTP, OTP/A, ITL Retained (Please circle one.)

Moved by Rep. *Rep Ingersoll*

Seconded by Rep. *Rep. Nedeau*

Vote: *ITL Rep. Ingersoll Rep. Nedeau, Rep. Hinch*

Motions: OTP, OTP/A, ITL, Retained (Please circle one.)

Moved by Rep.

Seconded by Rep.

Vote:

Respectfully submitted,
Rep. *David Ingersoll*
Subcommittee Chairman/Clerk

Sept 7, 2010

10:00 AM

HB-1405 = Review of Bill have requested this Bill be
I.T.L. at this time, let tech catch up with
it.

general talk of ~~with~~ what will be in a
couple of years.

Motion of I.T.L. Paul Ingersoll
(9-0) Steve Nedean.

~~Special Amber Plate~~

COFFEY

HINCH

INGERSOLL

NEDEAN

O'BRIEN

RHODES

WILLIAMS

UMBERGEN

STUART

Testimony

1926.601(b)(4)

OSHA Regs. (Mark Holden)

1926.601(b)(4)

No employer shall use any motor vehicle equipment having an obstructed view to the rear unless:

1926.601(b)(4)(i)

The vehicle has a reverse signal alarm audible above the surrounding noise level or:

1926.601(b)(4)(ii)

The vehicle is backed up only when an observer signals that it is safe to do so.

1926.601(b)(5)

All vehicles with cabs shall be equipped with windshields and powered wipers. Cracked and broken glass shall be replaced. Vehicles operating in areas or under conditions that cause fogging or frosting of the windshields shall be equipped with operable defogging or defrosting devices

SEC. 17. Penalties

- (a) Any employer who willfully or repeatedly violates the requirements of section 5 of this Act, any standard, rule, or order promulgated pursuant to section 6 of this Act, or regulations prescribed pursuant to this Act, may be assessed a civil penalty of not more than \$70,000 for each violation, but not less than \$5,000 for each willful violation. 29 USC 666
Pub. L. 101-508 increased the civil penalties in subsections (a)-(d) & (i). *See Historical notes.*
- (b) Any employer who has received a citation for a serious violation of the requirements of section 5 of this Act, of any standard, rule, or order promulgated pursuant to section 6 of this Act, or of any regulations prescribed pursuant to this Act, shall be assessed a civil penalty of up to \$7,000 for each such violation.
- (c) Any employer who has received a citation for a violation of the requirements of section 5 of this Act, of any standard, rule, or order promulgated pursuant to section 6 of this Act, or of regulations prescribed pursuant to this Act, and such violation is specifically determined not to be of a serious nature, may be assessed a civil penalty of up to \$7,000 for each violation.
- (d) Any employer who fails to correct a violation for which a citation has been issued under section 9(a) within the period permitted for its correction (which period shall not begin to run until the date of the final order of the Commission in the case of any review proceeding under section 10 initiated by the employer in good faith and not solely for delay or avoidance of penalties), may be assessed a civil penalty of not more than \$7,000 for each day during which such failure or violation continues.
- (e) Any employer who willfully violates any standard, rule, or order promulgated pursuant to section 6 of this Act, or of any regulations prescribed pursuant to this Act, and that violation caused death to any employee, shall, upon conviction, be punished by a fine of not more than \$10,000 or by imprisonment for not more than six months, or by both; except that if the conviction is for a violation committed after a first conviction of such person, punishment shall be by a fine of not more than \$20,000 or by imprisonment for not more than one year, or by both. Pub. L. 98-473 Maximum criminal fines are increased by the Sentencing Reform Act of 1984, 18 USC § 3551 et seq. *See Historical notes.*
- (f) Any person who gives advance notice of any inspection to be conducted under this Act, without authority from the Secretary or his designees, shall, upon conviction, be punished by a fine of not more than \$1,000 or by imprisonment for not more than six months, or by both. *See historical notes.*
- (g) Whoever knowingly makes any false statement, representation, or certification in any application, record, report, plan, or other document filed or required to be maintained pursuant to this Act shall, upon conviction, be punished by a fine of not more than \$10,000, or by imprisonment for not more than six months, or by both.
- (h) (1) Section 1114 of title 18, United States Code, is hereby amended by striking out "designated by the Secretary of Health and Human Services to conduct investigations, or inspections under the Federal Food, Drug, and Cosmetic Act" and inserting in lieu thereof "or of the Department of Labor assigned to perform investigative, inspection, or law enforcement functions".
- (2) Notwithstanding the provisions of sections 1111 and 1114 of title 18, United States Code, whoever, in violation of the provisions of section 1114 of such title, kills a person while engaged in or on account of the performance of investigative, inspection, or law enforcement functions added to such section 1114 by paragraph (1) of this subsection, and who would otherwise be subject to the penalty provisions of such section 1111, shall be punished by imprisonment for any term of years or for life.
- (i) Any employer who violates any of the posting requirements, as prescribed under the provisions of this Act, shall be assessed a civil penalty of up to \$7,000 for each violation.
- (j) The Commission shall have authority to assess all civil penalties provided in this section, giving due consideration to the appropriateness of the penalty with respect to the size of the business of the employer being charged, the gravity of the violation, the good faith of the employer, and the history of previous violations.

(k) For purposes of this section, a serious violation shall be deemed to exist in a place of employment if there is a substantial probability that death or serious physical harm could result from a condition which exists, or from one or more practices, means, methods, operations, or processes which have been adopted or are in use, in such place of employment unless the employer did not, and could not with the exercise of reasonable diligence, know of the presence of the violation.

(l) Civil penalties owed under this Act shall be paid to the Secretary for deposit into the Treasury of the United States and shall accrue to the United States and may be recovered in a civil action in the name of the United States brought in the United States district court for the district where the violation is alleged to have occurred or where the employer has its principal office.

The following diagram defines the backing zone. *Distances in feet.*

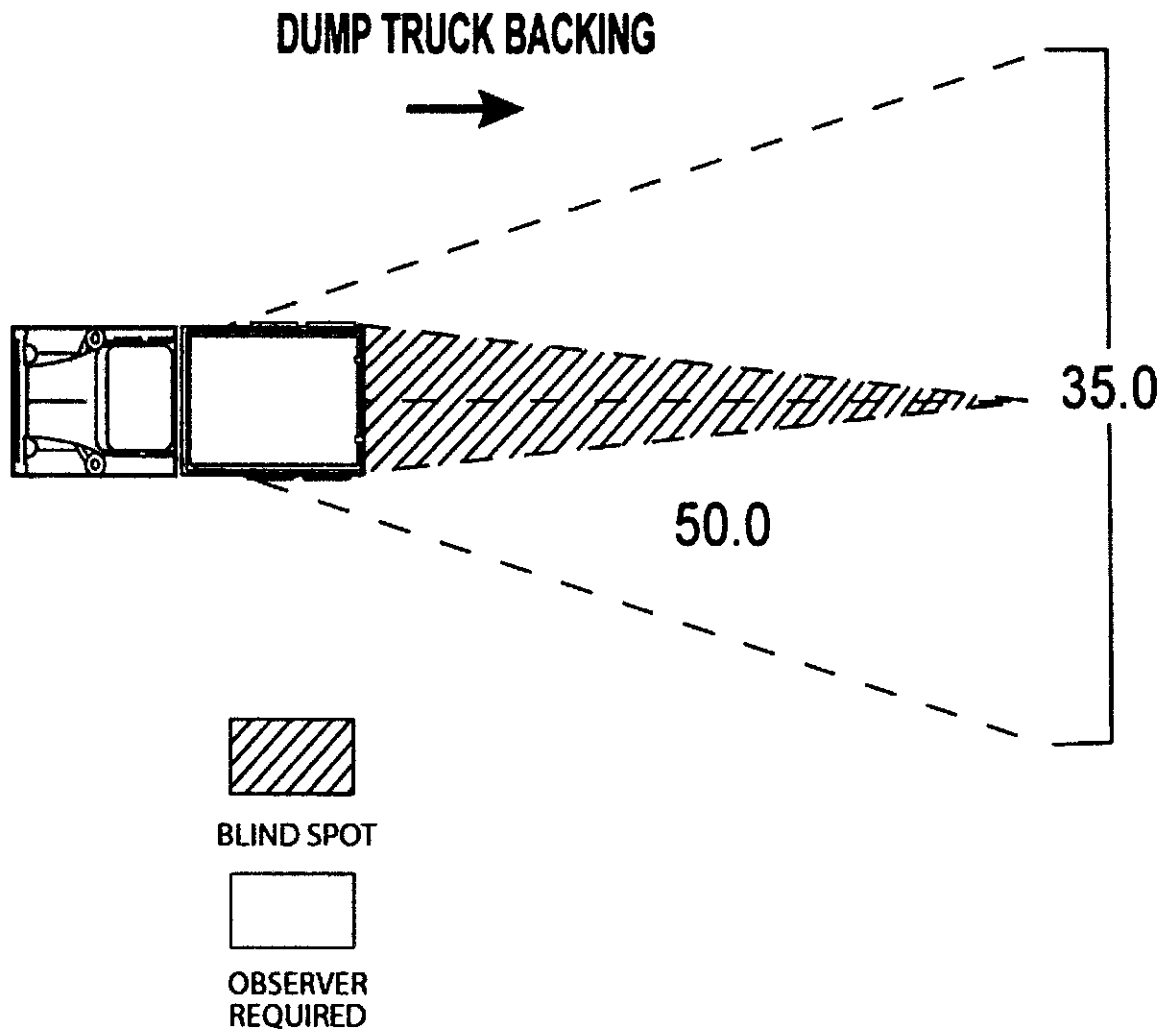

Voting Sheets

HOUSE COMMITTEE ON TRANSPORTATION

EXECUTIVE SESSION on HB 1405

BILL TITLE: relative to reverse signal operation safety requirements for construction equipment.

DATE: February 16, 2010

LOB ROOM: 203

Amendments: O'Brien/Coffey

Sponsor: Rep. Baldasaro OLS Document #: 2010 0742h

Sponsor: Rep. OLS Document #:

Sponsor: Rep. OLS Document #:

Motions: OTP, OTP/A, ITL, Interim Study (Please circle one.)

Moved by Rep. O'Brien Aye Recess for amendment

Seconded by Rep. Stuart

Vote: 13-1 (Please attach record of roll call vote.)

Motions: OTP, OTP/A, ITL, Interim Study (Please circle one.)

Subcommittee:
Ingersoll
Hebert
Nedeau

Moved by Rep. O'Brien

Seconded by Rep. Stuart

Vote: (Please attach record of roll call vote.)

CONSENT CALENDAR VOTE: Rokas/Soucy

(Vote to place on Consent Calendar must be unanimous.)

Statement of Intent: Refer to Committee Report

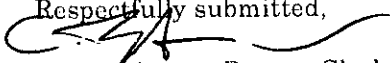
Respectfully submitted,

Rep. C. Pennington Brown, Clerk

HOUSE COMMITTEE ON TRANSPORTATION

EXECUTIVE SESSION on HB 1405

BILL TITLE: relative to reverse signal operation safety requirements for construction equipment.

DATE: 2/16/10

LOB ROOM: 203

Amendments: 0742h O'Brien / Coffee

Sponsor: Rep. Baldasano OLS Document #:

Sponsor: Rep. OLS Document #:

Sponsor: Rep. OLS Document #:

Motions: OTP, OTP/A, ITL, Interim Study (Please circle one.)

Moved by Rep. O'Brien / Stuart Ayle

Seconded by Rep. Stuart

Vote: 13-1 (Please attach record of roll call vote.)

Receipts for amend. OK

Motions: OTP, OTP/A, ITL, Interim Study (Please circle one.)

Moved by Rep. O'Brien

Seconded by Rep. Stuart

Vote: (Please attach record of roll call vote.)

Subcommittee Ingersoll Hebert Newland

CONSENT CALENDAR VOTE: Pokas/Baucus

(Vote to place on Consent Calendar must be unanimous.)

Statement of Intent: Refer to Committee Report

Respectfully submitted,

Rep. C. Pennington Brown, Clerk

TRANSPORTATION

Bill #: HB 1405 Title: relative to reverse signal operation safety require-
ments for construction equipment.

PH Date: Jan 20 / 2010 Exec Session Date: 2 / 16 / 10

Motion: Interim Study Amendment #: 0742h

MEMBER	YEAS	NAYS
Williams, Robert W, Chairman	--- X	
O'Brien, Michael B, V Chairman	X	
Brown, Jennifer M	---	
Brown, C. Pennington, Clerk	X	
Ingersoll, Paul H	X	
Hebert, Roger G	X	
LaPlante, Roland H	---	
Rhodes, Brian D	X	
Rokas, Theodoros V	X	
Soucy, Timothy A	X	
Stuart, Richard T	X	
Nedeau, Stephen H	X	
Katsakiores, George N	---	
Flanders, John W	X	
Veazey, John A	X	
Coffey, Jennifer R		X
Hikel, John A	---	
Hinch, Richard W	---	
Umberger, Karen C	X	
<i>N</i>		
TOTAL VOTE:	13	1

Committee Report

CONSENT CALENDAR

February 17, 2010

HOUSE OF REPRESENTATIVES

REPORT OF COMMITTEE

The Committee on TRANSPORTATION to which was referred HB1405,

AN ACT relative to reverse signal operation safety requirements for construction equipment. Having considered the same, report the same with the recommendation that the bill be REFERRED FOR INTERIM STUDY.

Rep. Michael B O'Brien

FOR THE COMMITTEE

COMMITTEE REPORT

Committee:	TRANSPORTATION
Bill Number:	HB1405
Title:	relative to reverse signal operation safety requirements for construction equipment.
Date:	February 17, 2010
Consent Calendar:	YES
Recommendation:	REFER TO COMMITTEE FOR INTERIM STUDY

STATEMENT OF INTENT

The transportation committee in a 13-1 vote determined that this bill should be referred to interim study due to the important merits of the bill. This bill as amended would place additional assistance to heavy equipment operators in electronic or human provisions to assist operators when they are backing up the equipment at job sites. This bill is known as Rob's Law and represents a construction worker who was killed in such a backing accident. The interim study committee will research federal law, as well as other state laws on this matter. They will also attempt to report back with recommendations for a bill that would meet NH standards of law.

Vote 13-1.

Rep. Michael B O'Brien
FOR THE COMMITTEE

Original: House Clerk
Cc: Committee Bill File

CONSENT CALENDAR

TRANSPORTATION

HB1405, relative to reverse signal operation safety requirements for construction equipment.
REFER TO COMMITTEE FOR INTERIM STUDY.

Rep. Michael B O'Brien for TRANSPORTATION. The transportation committee in a 13-1 vote determined that this bill should be referred to interim study due to the important merits of the bill. This bill as amended would place additional assistance to heavy equipment operators in electronic or human provisions to assist operators when they are backing up the equipment at job sites. This bill is known as Rob's Law and represents a construction worker who was killed in such a backing accident. The interim study committee will research federal law, as well as other state laws on this matter. They will also attempt to report back with recommendations for a bill that would meet NH standards of law. **Vote 13-1.**

Original: House Clerk
Cc: Committee Bill File

Blurb

HB 1405 relative to reverse signal operation safety requirements for construction equipment.

Consent Calendar Interim Study

The transportation committee in a 13-1 vote determined that this bill should be referred to interim study due to the important merits of the bill. This bill as amended would place additional assistance to heavy equipment operators in electronic or human provisions to assist operators when they are backing up the equipment at job sites. This bill is known as Rob's Law and represents a construction worker who was killed in such a backing accident. The interim study committee will research federal law, as well as other state laws on this matter. They will also attempt to report back with recommendations for a bill that would meet NH standards of law.

13-1

Rep. Michael O'Brien
for the committee



O'Brien

COMMITTEE REPORT

COMMITTEE: TRANSPORTATION

BILL NUMBER: HB 1405

TITLE: relative to reverse signal operation safety requirements for construction equipment.

DATE: 2/16/10 CONSENT CALENDAR: YES NO

meas

- OUGHT TO PASS
- OUGHT TO PASS W/ AMENDMENT
- INEXPEDIENT TO LEGISLATE
- INTERIM STUDY (Available only 2nd year of biennium)

Amendment No. <u>2010-0742</u>

STATEMENT OF INTENT:

The Transportation in a 13-1 vote determined that this bill should be referred to Interim Study due to the important merits of the bill. This bill as amended would place additional assistance to Heavy Equipment operators in electronic or human provisions to assist operators when they are backing up the equipment at job sites. This Bill is known as Rob's law ^{and} who represents a construction worker who was killed in such a backing accident. The Interim Study Committee will Research Federal Law, as well as other state laws on this matter. They will also with attempt to report back with recommendations for a bill that would meet Nbl Standards of Law.

COMMITTEE VOTE: 13-1

(RM)

RESPECTFULLY SUBMITTED,

- | |
|-----------------------------------------------------------------------------------------------------------------------------------|
| <ul style="list-style-type: none"> • Copy to Committee Bill File • Use Another Report for Minority Report |
|-----------------------------------------------------------------------------------------------------------------------------------|

Rep. Michael J. O'Brien
For the Committee